

THREADBAR® Anchors



THREADBAR® Anchors

THREADBAR® Anchor System.....	4
Design Considerations	5
THREADBAR® System for Bar Anchors.....	6
THREADBAR® Anchors with Double Corrosion Protection (DCP).....	7
THREADBAR® Anchor Properties and Dimensions	8
GEWI® Threadbar Anchor Properties and Dimensions	9
THREADBAR® Anchor Hardware & Tensioning Equipment	10
On-site Assembly and Installation Instructions for DCP Threadbar Anchors.....	11



General Notes

Today, DSI is a world leader in the development of bar anchor systems and technology. The Double Corrosion Protected (DCP) THREADBAR® anchor is universally recognised as the “standard” for anchor performance and corrosion protection.

As a full service organisation, DSI is prepared to supply design assistance and practical field know-how. This service can also be used to optimise the design process, by helping to select the anchor system best suited to meet specific project requirements. To minimise site labour and to optimise quality control, a variety of shop prefabricating services are available for THREADBAR® anchors.

Advantages

Simple and Rugged

The THREADBAR® has a continuous coarse thread hot-rolled on two opposite sides which allows anchorage hardware or couplers to thread onto the bar at any point. The coarse thread is almost indestructible under normal job site conditions and insensitive to dirt. In addition, there is no loss of strength due to thread cutting. Every bar is proof stressed to its yield and stress relieved at the mill to improve their relaxation & fatigue characteristics.

Positive Anchorage

The bar is anchored using a threaded nut, which, unlike a wedge type anchorage, is not liable to slip when the anchor force is reduced due to possible ground movements.

Easy to Splice

The continuous thread makes it possible to extend the THREADBAR® to any length, simplifying transportation and installation. Extending the bar beyond the stressing end to connect to another structural member is also a simple operation.

High Bond Strength

The coarse continuous thread provides excellent bond between the bar and cement grout, making it possible for a reliable transfer from the anchor prestress load into the grout without the need for additional mechanical devices. The narrow spacing of the thread assures close crack spacing in the surrounding grout and therefore the smaller crack width further supports the corrosion protection.

Easy to Stress

The reliable threaded nut anchorage has almost no anchor set. Its hemispherical shape easily accommodates the small angular misalignments between bar and anchorage due to construction tolerances. Lightweight, durable equipment makes stressing, re-stressing and adjusting the anchor load up or down easy to do.

Easy to Check Actual Prestress Load & Restress

The threaded design makes it possible to make a lift off test/or adjust the anchor load at any time during the service life of the anchor. Corrosion protection can be maintained at all times.

Removable

The THREADBAR® can be removed after de-stressing the anchor by unscrewing the unbonded portion of the bar from a coupler or out of an embedded end anchorage. Bars with end anchors and sleeved within the bond length can be completely removed. This is especially important where temporary anchors are installed below adjacent properties and must be removed after use.

Unprotected Anchors

Unprotected anchors are used for temporary applications. The free stressing length is debonded while the bond length is embedded in the cement grout body.

Corrosion Protection Options

For permanent applications, a wide variety of corrosion protection options are available to choose from depending upon the expected length of service and the aggressiveness of the environment.

Insurance Against Anchor Failure

In cohesive and other poor soils, a proven and reliable DSI Post-grouting System can be used to increase the capacity of an anchor.

Design Considerations

Prestressed bar anchors have become an important tool for geotechnical engineers. Their safe and reliable use in both permanent and temporary applications is accepted throughout the world.

Soil Anchors are post-tensioned-tendons installed in either cohesive or non-cohesive soil or loose rock. In the bond length, the anchors transfer forces into the ground by means of a steel tendon and a well defined grout body. In the free stressing length the anchor remains unbonded and free to move during tensioning.

Soil anchors are generally used to:

- Anchor support structures for excavations such as sheet pile walls, soldier piles and lagging, drilled piles and slurry walls

- Counteract uplift forces in structures subjected to buoyancy and lateral loads
- Transfer external forces to the ground; e.g. wind, earthquake
- Stabilise eccentrically loaded foundations
- Stabilise material or excavated slopes.

Rock Anchors are post-tensioned tendons installed in drilled holes for which at least the entire bond length is located in rock. The anchor force is transmitted to the rock by bond between the grout body and the rock. Rock anchors can remain unbonded in the free stressing length allowing the anchor to be checked and re-tensioned at any time. In such cases, adequate corrosion protection for the stressing anchorage and the free stressing length

must be provided. On the other hand, the free stressing length can also be fully grouted after the anchor has been stressed, in which case force adjustment is no longer possible.

Rock anchors are generally used to:

- Anchor external forces and uplift forces
- Anchor retaining walls
- Stabilise eccentrically loaded foundations, slopes, rock walls and cuts
- Stabilise underground excavations and tunnels
- Increase the stability of dams against overturning and uplift.

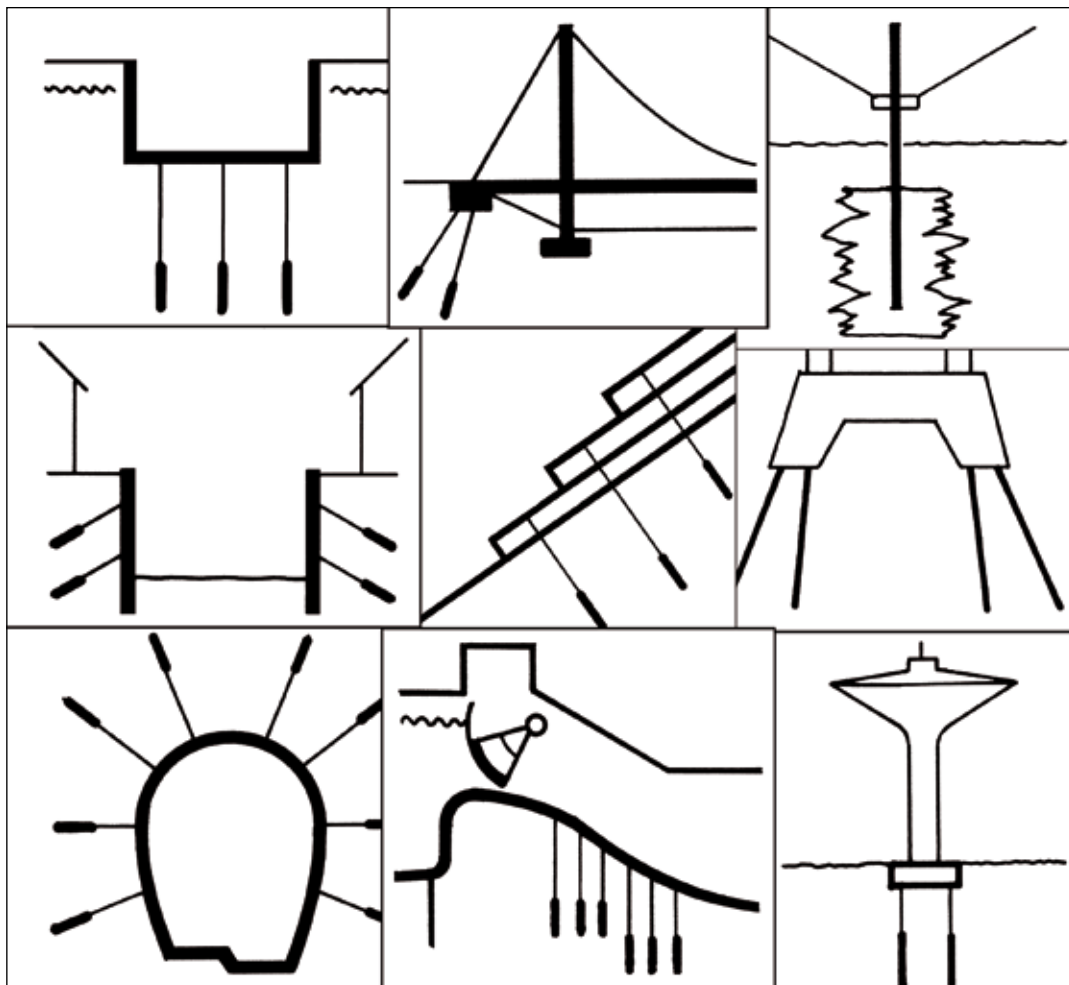

THREADBAR® System for Bar Anchors

THREADBAR® Anchors with Single Corrosion Protection (SCP)

Single corrosion protected anchors are used for temporary applications. In highly corrosive environments, the free stressing length is coated with a corrosion inhibitor and covered with smooth sheathing. Spacers are installed over the bond length to allow full grout cover in order to provide bond to the surrounding drilled hole. The entire length is covered with cement grout.

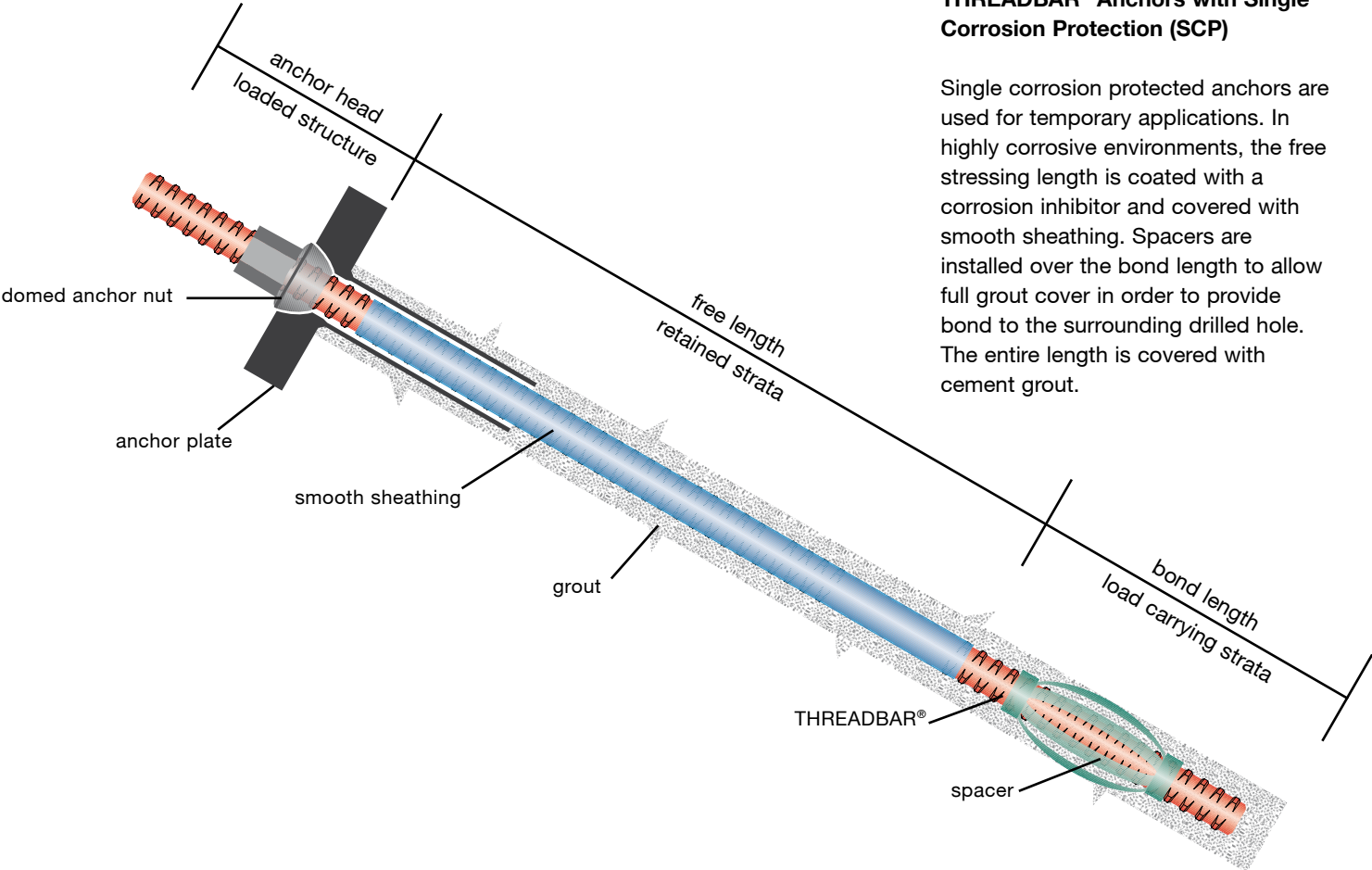

THREADBAR® Anchors with Double Corrosion Protection (DCP)

DCP anchors are recommended for anchors with a long service life and for an environment where aggressive materials are expected.

The DSI permanent THREADBAR® anchors use a double corrosion protection system to fully encapsulate the steel bars over their entire length. It consists of cement grout injected into the annular space between the centralised THREADBAR® and the high strength corrugated PVC sheathing over the bond and free lengths. The cement grout inside the corrugated sheathing acts as the first level of protection embedding the bar in an alkaline environment.

The corrugated PVC sheathing is impermeable to any corrosive substances such as ground water and gases and acts as the second level of protection. Permanent anchors are pre-grouted in a controlled factory environment to ensure adequate corrosion protection during transport, storage, installation and design life.

In the bond length, the corrugations of the sheathing transfer the load to the grout in the drilled hole. In the free length, the load transfer is prevented by inserting smooth sheathing over the corrugated sheathing.

In order to accommodate for elongation of the anchor during tensioning, a short segment of the THREADBAR® remains ungrouted underneath the anchor plate. Full encapsulation is provided at this location by a steel tube welded to the underside of the plate and fits tightly over the sliding seals at the top of the free length. In addition, the steel tube is filled with anti-corrosion compound.

The anchor nut and the bar above the anchor plate are covered by removable protective caps filled with anti-corrosion compound. Caps can be made of either plastic or hot-dipped galvanised steel. This design permits re-stressing, de-stressing and load monitoring at any time.

The two levels of corrosion protection for couplers in both the bond and free lengths are achieved by applying anti-corrosion compound to the bar and coupler and covering the splice with a heat-shrink sleeve. For couplers in the free length, an additional debonding tube is inserted over the DCP couplers to ensure free movement of the couplers during stressing.

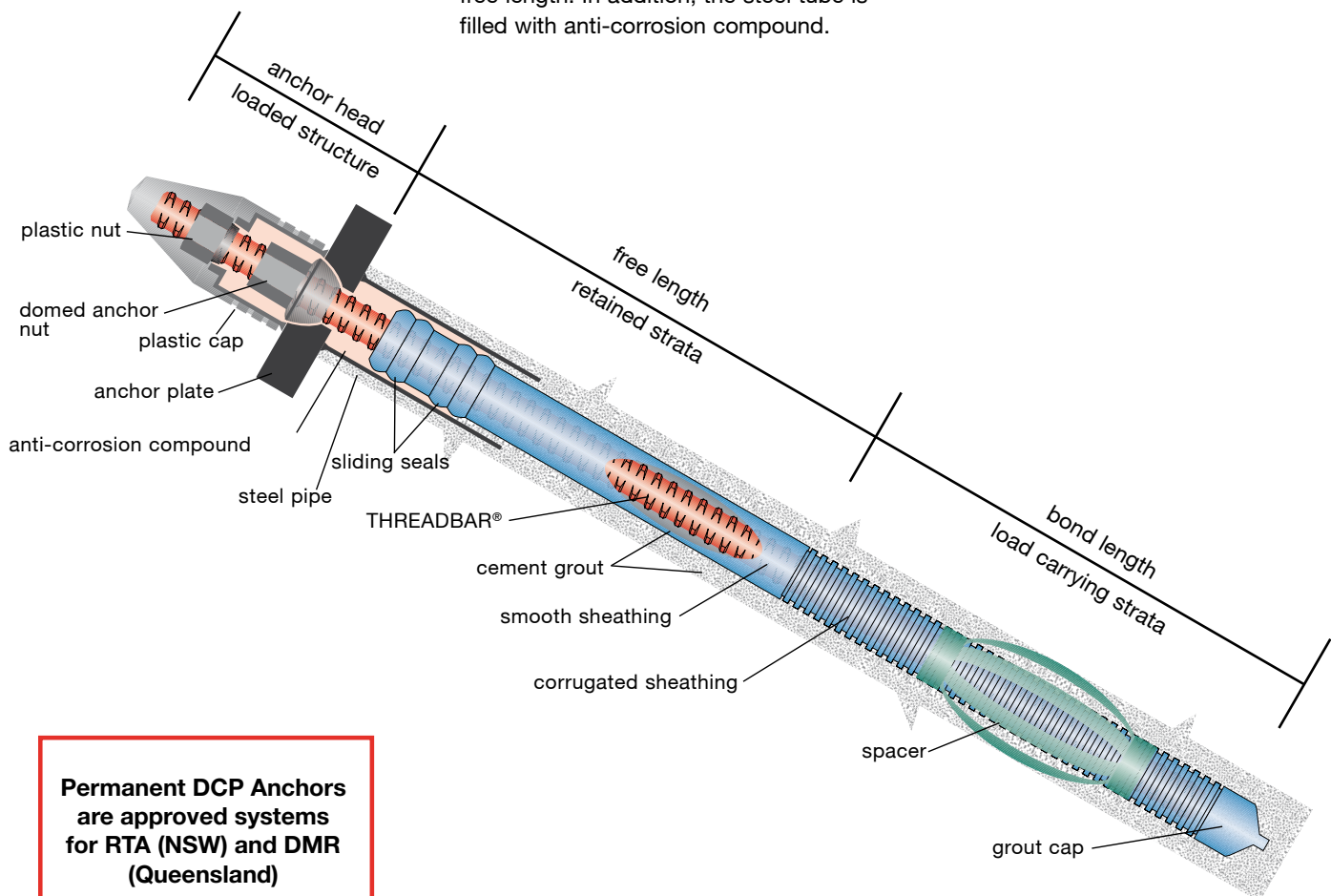

**Permanent DCP Anchors
are approved systems
for RTA (NSW) and DMR
(Queensland)**

THREADBAR® Anchor Properties: WR Grade

Nominal Diameter (mm)	26.5	32	36	40
Minimum Ultimate Steel Grade (MPa)	1,050	1,050	1,050	1,050
Minimum Yield Steel Grade (MPa)	950	950	950	950
Minimum Breaking Load (kN)	579	844	1,069	1,319
Minimum Yield Load (kN)	524	764	967	1,194
Cross-Section Area (mm ²)	552	804	1,018	1,257
Maximum Thread Diameter (mm)	30.5	36.3	41.4	45.3
Unit Weight (kg/m)	4.48	6.53	8.27	10.21
Minimum Bar Protrusion P* (mm)	85	100	105	125

THREADBAR® Anchor Hardware Dimensions

Nominal Diameter (mm)	26.5	32	36	40
Domed Nut L (mm)	60	72	75	83
A/F** (mm)	50	60	65	70
Hex Nut L (mm)	85	105	120	120
A/F** (mm)	50	60	65	70
Coupler C (mm)	170	200	210	250
D (mm)	55	65	72	71
Typical Plate for Rock Anchors W (mm)	180	200	220	240
T (mm)	40	45	50	55
Corrugated Sheathing Diameter (mm)	50	60	65	65
Smooth Sheathing Diameter (mm)	60	72	75	75

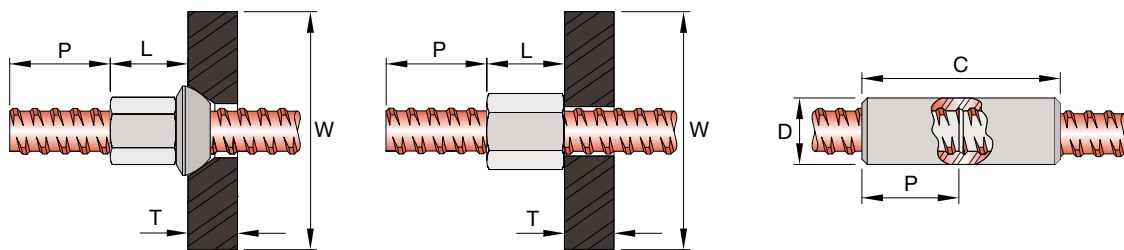

Notes:

*Minimum THREADBAR® protrusion to accommodate tensioning or coupling: $P = \frac{1}{2}C$ (mm).

**Width measured across flat of nut.

GEWI® Threadbar Anchor Properties: T Grade

Nominal Diameter (mm)	20	25	28	32	40	50	63.5
Minimum Ultimate Steel Grade (MPa)	600	550	550	550	550	550	700
Minimum Yield Steel Grade (MPa)	500	500	500	500	500	500	555
Minimum Breaking Load (kN)	188	270	339	442	691	1,080	2,217
Minimum Yield Load (kN)	157	245	308	402	628	982	1,758
Cross-Section Area (mm ²)	314	491	616	804	1,257	1,964	3,167
Minimum Thread Diameter (mm)	22.8	27.9	31.6	35.7	44.2	55.6	69.0
Unit Weight (kg/m)	2.47	3.85	4.83	6.31	9.86	15.41	24.86
Minimum Bar Protrusion P* (mm)	55	58	63	70	80	100	130

GEWI® Threadbar Anchor Hardware Dimensions

Nominal Diameter (mm)	20	25	28	32	40	50	63.5
Domed Nut L (mm)	35	40	46	51			
A/F** (mm)	36	38	43	46			
Hex Nut L (mm)	35	50	55	60	70	85	115
A/F** (mm)	36	41	46	55	65	80	100
Coupler C (mm)	110	115	125	140	160	200	260
D (mm)	37	42	48	55	68	84	106
Domed Plates W (mm)	150	150/200	200				
T (mm)	8/10	10/12	16				
Flat Plates W (mm)			200	200/250	250	250	200
T (mm)			16/20	20/25	20/25	20/25	25
Corrugated Sheathing Diameter (mm)	50	50	56	56	65	80	100

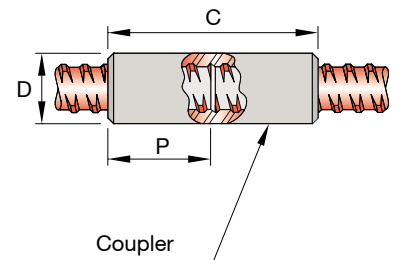
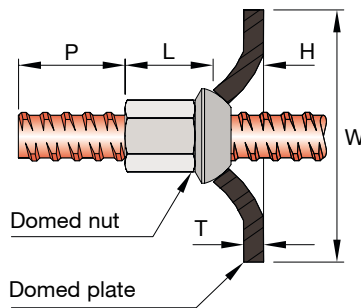
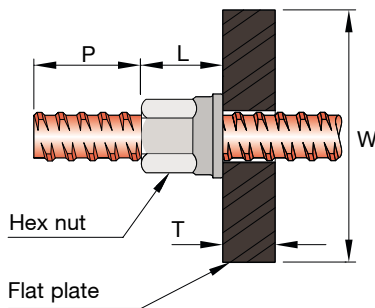

Notes:

*Minimum THREADBAR® protrusion to accommodate tensioning or coupling: $P = \frac{1}{2}C$ (mm).

**Width measured across flat of nut.

THREADBAR® Anchor Hardware

Domed Nut

- The spherical sheathing allows for small angle compensation (3-4°)
- The width across the flat of the hex portion matches the tightening socket inside the DSI jack
- Protective caps are available.

Flat Plate for Rock Anchors

- Installed on flat bearing surfaces
- Various dimensions and grouting hole positions are available
- Hot-dipped galvanising is required for permanent applications.

Coupler

- Used for extending to the desired length
- Double corrosion protection is required for permanent applications
- Couplers are designed and produced to exceed the tensile capacity of the bars

Slip-on or Segment Spacers

- Installed on the anchors to ensure a grout cover around the anchor inside the drilled hole.

Grout Tube

- Grout tube is used to inject cement grout
- Grout tubes are manufactured from polyethylene material.

THREADBAR® Anchor Tensioning Equipment

Tensioning jacks are available for customer hire. Every DSI tensioning jack is calibrated with its corresponding hydraulic gauge.

During bar tensioning, the operator tightens the nut by pulling on a ratchet handle linked to a socket which fits over the anchor nut.

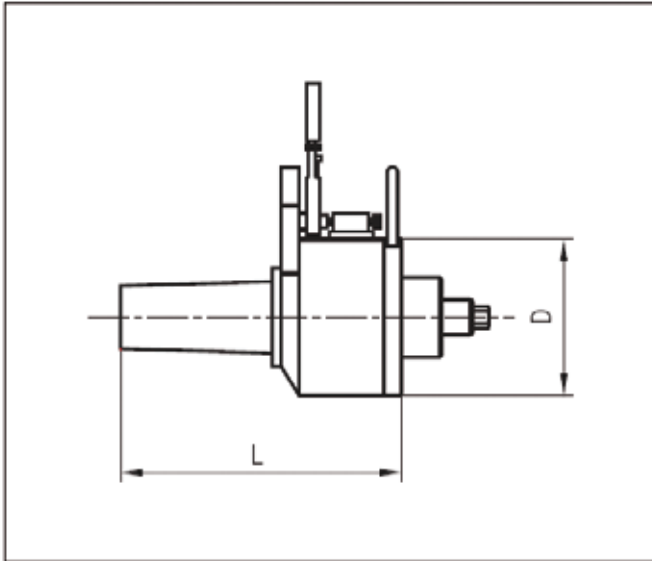

Jack 600kN Series 04

Jack Type	Length L (mm)	Diameter D (mm)	Stroke (mm)	Piston Area (cm ²)	Weight (kg)
600kN	400	190	50	132.5	36
1,100kN	494	267	50	235.6	46
1,100kN	594	267	150	235.6	54
1,500kN	870	336	250	302.4	125

On-site Assembly and Installation Instructions for DCP Threadbar Anchors

1. Receiving the anchors

- Check for possible transportation damage.
- Do not use anchors that have been bent or that have any surface damage, do not use bars as ground for welding, do not allow hot slag to touch the bars, do not weld to bars.
- Handle anchors with care using nylon lifting slings (2 legs minimum).
- Upon unloading, protect the bars from dirt and mechanical damage.
- Important: the bars must not be dropped, thrown or dragged.

2. DCP couplers in the bond and free lengths

- Grease both bar ends thoroughly.
- Install coupler, bar ends must be centred inside coupler.
- Torque bar against each other.
- If applicable, tighten set-screws against flat side of the bar.
- Grease coupler thoroughly.
- Install heat-shrink sleeve. Important: do not burn the heat-shrink sleeve nor the plastic sheathing.

3. DCP couplers in the free length only

- Centre coupler tube over the heat-shrink sleeve (refer to 2. above) allowing for displacement of the heat-shrink sleeve during stressing.
- Secure coupler tube firmly by taping both end to the smooth sheathing.

4. Grout tube and outer spacer assembly

- Install outer spacers (alternatively: segment spacers) within the bond length using adhesive tape and/or wire at the required spacing.
- If applicable, install grout tube using adhesive tape. The grout tube must start 50 to 100mm from the bottom of the anchor and extend at least 1 metre above the anchor head.

5. Installing the bar plates and bar nuts

- Install anchor plates pre-filled with anti-corrosion compound over the bar leaving enough bar protruding behind the plate for the anchor nut and the stressing coupler. Also, ensure that there is sufficient bare bar (typically 100 mm) inside the steel tube welded to the steel plate to allow for free movement of the vent cap during tensioning of the anchor.
- Screw anchor nut tight against the bearing plate making sure that the spherical end of the nut contacts the plate.

6. Installing the bearing & wedge washer and anchor nut

- Install the wedge washer (2 pcs maximum) followed by the bearing washer with welded steel tube prefilled with anti-corrosion compound over the bar leaving enough bar protruding behind the plate for the anchor nut and the stressing coupler. Also, ensure that there is sufficient bare bar inside to steel tube welded to the steel plate to allow for free movement of the vent cap during tensioning of the anchor.
- Screw anchor nut hand tight against the bearing plate making sure that the spherical end of the nut contacts the plate.

7. Inserting the anchor into the borehole

- If necessary, water-test the borehole according to the project specifications.
- Using a lifting eye or another equivalent attachment, lift the anchor from the anchor head end, Important: do not drag.
- Insert the anchor into the borehole gradually making sure that it does not get damaged.

8. Grouting the anchors with plates and nuts installed

- Grout the anchor along its entire length in one stage according to the project specifications.

9. Grouting the anchors without plates and nuts installed

- Ensure that the anchor is centred in the borehole.
- Leave enough bar protruding behind the plate for the anchor nut and the stressing coupler. Also, ensure that there will be sufficient bare bar inside the steel tube welded to the steel plate to allow for free movement of the vent cap during tensioning of the bar. Grout the entire anchor in one stage according to the project specifications.
- While the grout is still wet, wash-out half a metre below the location of the anchor plate.
- Install the anchor plate and nut as instructed above (Installing the anchor plates and anchor nuts).
- Tremmie grout the entire void behind the plate.

10. Testing and stressing

- Stress the bars according to project specifications and contract drawings. CAUTION: the stressing equipment is capable of developing very large forces. Read the safety and operating instructions.

11. Installing protective caps

- Pre-fill the caps with anti-corrosion compound and install it over the anchor nut with corresponding seals.

Tunneling and Civil

DYWIDAG-SYSTEMS
INTERNATIONAL PTY. LIMITED
25 Pacific Highway
Bennetts Green NSW 2290
Australia
Phone +61-2-49 48 90 99
Fax +61-2-49 48 40 87
E-mail dsi@dywidag.com.au
www.dsicivil.com.au

DSI Australia Tunneling and Civil
Products Division is Quality
Assured to ISO 9001: 2000
Registration No.
QAC/R61/0315

Approvals available upon request.

Please note:

This brochure serves basic information purposes only. Technical data and information provided herein shall be considered non-binding and may be subject to change without notice. We do not assume any liability for losses or damages attributed to the use of this technical data and any improper use of our products. Should you require further information on particular products, please do not hesitate to contact us.

ARGENTINA
AUSTRALIA
AUSTRIA
BELGIUM
BOSNIA AND HERZEGOVINA
BRAZIL
CANADA
CHILE
CHINA
COLOMBIA
COSTA RICA
CROATIA
CZECH REPUBLIC
DENMARK
EGYPT
ESTONIA
FINLAND
FRANCE
GERMANY
GREECE
GUATEMALA
HONDURAS
HONG KONG
INDONESIA
ITALY
JAPAN
KOREA
LEBANON
LUXEMBOURG
MALAYSIA
MEXICO
NETHERLANDS
NORWAY
OMAN
PANAMA
PARAGUAY
PERU
POLAND
PORTUGAL
QATAR
RUSSIA
SAUDI ARABIA
SINGAPORE
SOUTH AFRICA
SPAIN
SWEDEN
SWITZERLAND
TAIWAN
THAILAND
TURKEY
UNITED ARAB EMIRATES
UNITED KINGDOM
URUGUAY
USA
VENEZUELA

www.dsicivil.com.au