

DYWIDAG Multistrand Anchors



DYWIDAG Multistrand Anchors

DYWIDAG Multistrand Anchor System 4
DYWIDAG Multistrand Anchor Properties and Dimensions 6
DYWIDAG Multistrand Anchor Equipment..... 7



DYWIDAG Multistrand Anchor System

General Notes

DYWIDAG Multistrand Rock and Soil Anchor System is based on the proven prestressing technology of the DYWIDAG Post-Tensioning System and decades of experience in anchor technology. The system is extremely versatile and can be adapted to meet almost any project requirement. Because of their small bending radius, strand anchors can easily be coiled to fit on trucks and are well suited for installation where work space is limited.

Advantages

- Little space required during transport, storage and installation when coiled in the factory
 - Sturdiness against damage ensured through flexibility
 - Double corrosion protection is supplied for permanent anchors
 - Easy installation due to relatively low weight
 - Practically no limitation of the working load due to an optional number of strands
- Consistent high quality product due to internal supervision of production
 - Each strand is opened, coated with corrosion inhibitor, then closed and inserted in individual sheaths prefilled with corrosion inhibitor
 - Pre-fabricated in the factory, minimising assembly time and labour costs on the job site.



DYWIDAG Multistrand Anchor System

DYWIDAG Multistrand Anchor - Double Corrosion Protection (DCP)

DCP Anchors are used for permanent applications in aggressive or uncertain environments.

Corrugated polyethylene (PE) sheathing covers both the bond and free stressing lengths. The bottom of the sheathing is sealed with an end cap, the top fits inside a grease-filled steel pipe that is welded to the underside of the plate.

Within the bond length, the strands are bare and separated by installing internal spacers to ensure bond to the surrounding grout. Within the free stressing length, each strand is greased and individually sheathed in order to ensure that it is free from the

surrounding grout to allow for tensioning of the anchor. This is achieved in the factory by opening every individual wire of a single strand, passing them through a hot-grease chamber, closing the strand by re-winding it and finally inserting the greased strand into a grease-filled PE tube. This ensures that there is no void and therefore no corrosion ingress.

The anchor head consists of a bearing plate that transfers the anchor loads to the rock or structure, a wedge plate with tapered holes and 3-part wedges that grip onto the strands. During tensioning the strands are pulled simultaneously with a multistrand hydraulic jack, resulting in the strands stretching within the free length.

When the desired load is achieved, the wedges are pushed against the wedge plate, the tensioning jack is released and the wedges grip on the strands as they are drawn into the tapered wedge plate holes.

Hot-dipped galvanised steel protective caps are placed over the wedge plates after tensioning.

All DYWIDAG multistrand jacks are self-centering by bearing directly on a locating ring that is machined on the wedge plates. This is to prevent wire breakage due to misalignment and also reduces wedge seating losses.

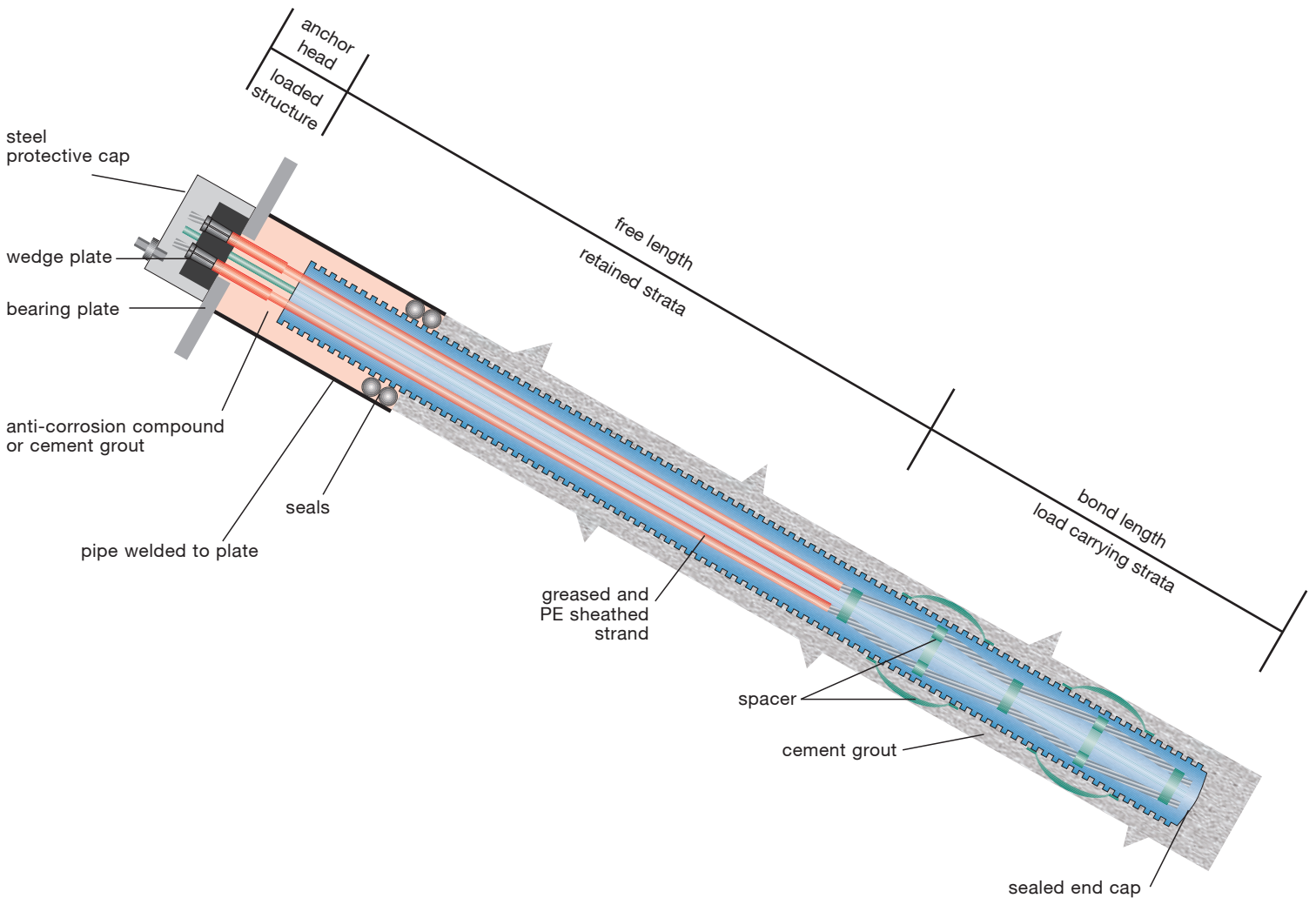

DYWIDAG Multistrand Anchor Properties and Dimensions

Super Grade Strand

Number of Strands	4	7	12	15	19
Area (mm ²)	572	1,001	1,716	2,145	2,717
Weight (kg/m)	4.49	7.85	13.46	16.83	21.32
Yield (kN)	820	1,435	2,430	3,075	3,895
UTS (kN)	1,000	1,750	3,000	3,750	4,750

Extra High Tensile Strand

Number of Strands	4	7	12	15	19
Area (mm ²)	572	1,001	1,716	2,145	2,717
Weight (kg/m)	4.49	7.85	13.46	16.83	21.32
Yield (kN)	856	1,498	2,568	3,210	4,066
UTS (kN)	1,044	1,827	3,132	3,915	4,359

Note: Other strand quantities available upon request.

DYWIDAG Multistrand Anchor Hardware

Number of Strands		4	7	12	15	19
Bearing Plate	W (mm)	230	230	290	340	390
	T (mm)	32	32	36	36	40
Pipe Sleeve	OD (mm)	102	102	114	114	140
	L (mm)	350	350	450	550	550
Corrugated Sheathing	OD (mm)	65	85	96	96	125

DYWIDAG Multistrand Anchor Equipment

Tensioning of DYWIDAG Multistrand Anchors

All jacks are calibrated with their respective pressure gauges. For installation and stressing efficiency, most DYWIDAG jacks for multistrand anchors are equipped with internal strand guide tubes and automatic strand gripping and releasing devices.

These features make jack installation a fast, one-step operation with small wedge seating loss.

For safety, all jacks feature a check valve which holds the pressure in the unlikely event of hydraulic failure.

For reliability, the jacks are equipped with a special plate for seating all wedges simultaneously.

DYWIDAG Strand Anchor Jacks

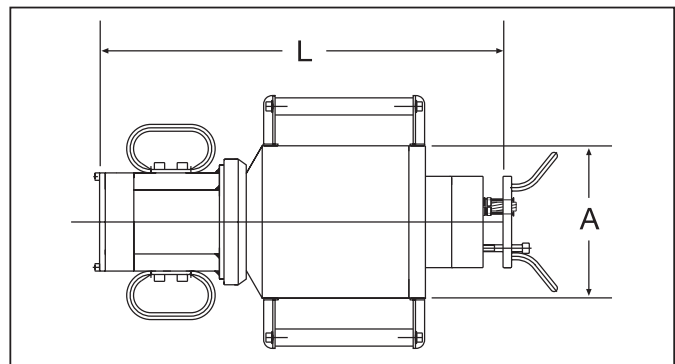

Jack 1,500 kN

Jack Type	Length L (mm)	O. D. A (mm)	Stroke (mm)	Piston Area (cm ²)	Capacity (kN)	Weight (kg)
1,100 kN	720	267	150	235.6	1,200	81
1,500 kN	870	336	250	302.4	1,500	125
HOZ 3,000	1,200	385	250	508.9	3,053	400
HOZ 5,000	1,462	482	250	894.6	4,200	600

Strand: Super Grade and extra High Tensile

No. of strands	2	3	4	5	6	7	8	9	10	11	12	13	14	15	16	17	18	19	20	21	22
1,100 kN	●	●	●	○	○	○															
1,500 kN	○	○	○	●	●	●															
HOZ 3,000							●	●	●	●	●										
HOZ 5,000												●	●	●	●	●	●	●	●	●	●

● Standard ○ Optional

Tunneling and Civil

DYWIDAG-SYSTEMS
INTERNATIONAL PTY. LIMITED
25 Pacific Highway
Bennetts Green NSW 2290
Australia
Phone +61-2-49 48 90 99
Fax +61-2-49 48 40 87
E-mail dsi@dywidag.com.au
www.dsicivil.com.au

ALWAG Tunnelausbau
Gesellschaft m.b.H
Wagram 49
4061 Pasching/Linz
Austria
Phone +43-7229-6 10 49 0
Fax +43-7229-6 10 49 80
E-mail office@alwag.com
www.alwag.com

American Commercial Incorporated (ACI)
Corporate Office & Bristol Plant
200 Bob Morrison Boulevard
Bristol, VA 2401-3801
USA
Phone +1-276-4 66 27 43
Fax +1-276-6 69 09 40
E-mail info@americancommercial.com
www.americancommercial.com

DSI Australia Tunneling and Civil
Products Division is Quality
Assured to ISO 9001: 2000
Registration No.
QAC/R61/0315

Approvals available upon request.

Please note:

This brochure serves basic information purposes only. Technical data and information provided herein shall be considered non-binding and may be subject to change without notice. We do not assume any liability for losses or damages attributed to the use of this technical data and any improper use of our products. Should you require further information on particular products, please do not hesitate to contact us.

ARGENTINA
AUSTRALIA
AUSTRIA
BELGIUM
BOSNIA AND HERZEGOVINA
BRAZIL
CANADA
CHILE
CHINA
COLOMBIA
COSTA RICA
CROATIA
CZECH REPUBLIC
DENMARK
EGYPT
ESTONIA
FINLAND
FRANCE
GERMANY
GREECE
GUATEMALA
HONDURAS
HONG KONG
INDONESIA
IRAN
ITALY
JAPAN
KOREA
LEBANON
LUXEMBOURG
MALAYSIA
MEXICO
NETHERLANDS
NORWAY
OMAN
PANAMA
PARAGUAY
PERU
POLAND
PORTUGAL
QATAR
RUSSIA
SAUDI ARABIA
SINGAPORE
SOUTH AFRICA
SPAIN
SWEDEN
SWITZERLAND
TAIWAN
THAILAND
TURKEY
UNITED ARAB EMIRATES
UNITED KINGDOM
URUGUAY
USA
VENEZUELA

www.dsicivil.com.au