

## DYWIDAG Ductile Iron Pile

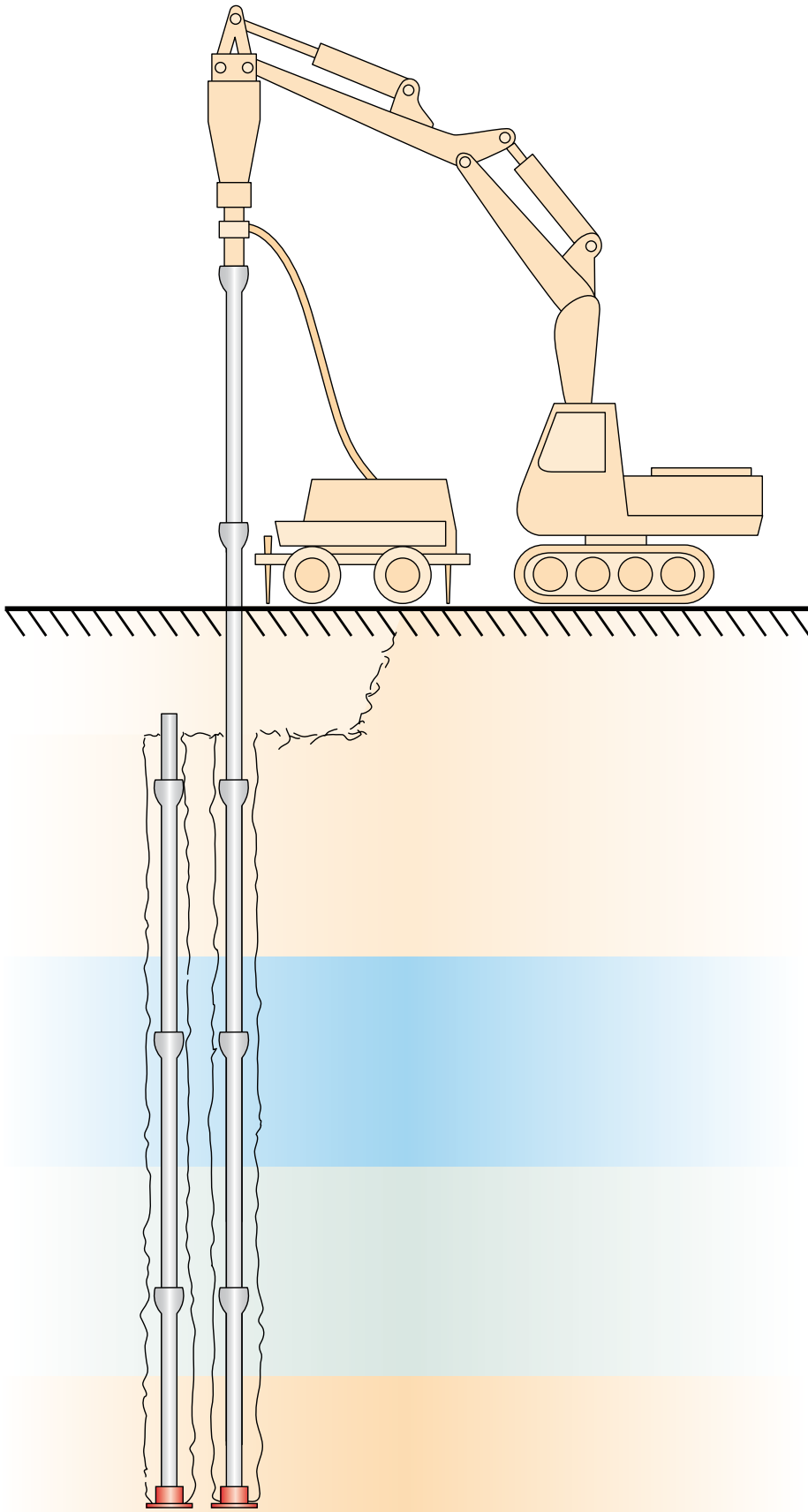





Applications **page 7**

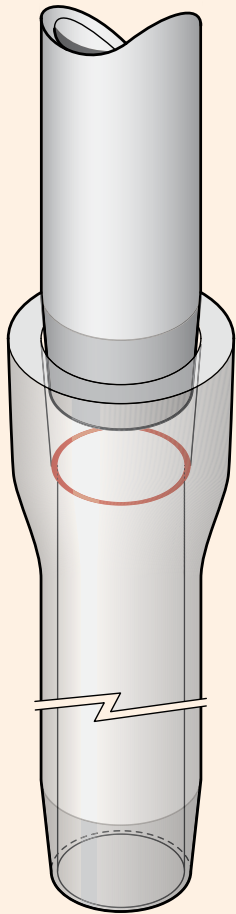

DYWIDAG Ductile Iron Pile **page 4**

---

DYWIDAG Ductile Iron Piles.....	4
Driven Piles.....	5
Accessories.....	6
Applications.....	7
Material.....	8
Corrosion Assessment.....	9
References.....	10

---

References **page 10**



DYWIDAG Ductile Iron Pile with grouted annulus **page 5**

## DYWIDAG Ductile Iron Piles

The DYWIDAG Ductile Iron Pile is a driven pile system, utilizing high strength ductile cast iron. Pile sections are connected together by a unique spigot and socket joint, which offers speed of connection together with a high degree of stiffness. The piles are installed in a quick succession using an excavator with a hydraulic hammer, to both pitch and drive each pile section.

Manufactured as Ductile Cast Iron, also known as Spheroidal Graphite Cast Iron, the system is immensely strong and offers superior durability over conventional tubular steel piles. Additional compressive strength is provided by the concreting or grouting of the bore, to form a composite pile.

Installed as an End-Bearing Pile (dry driven to a set, followed by concreting of the bore) or a Skin Friction Pile (simultaneous drive and grout, with an oversize shoe), the Ductile Iron Pile can accommodate a range of different ground conditions.

### Advantages

- Spigot and socket joint for quick and easy connection of pile sections
- Very fast and almost vibration free pile production
- High production rates of up to 400 m per day
- Control of load capacity through correlation with driving rate
- Can be used as a permanent pile
- Easy adaption of the pile length to different soil conditions
- No off-cuts or wastage
- Quick assembly of pile heads
- Light and versatile installation equipment allows pile productions under limited space conditions and in difficult terrain

### Spigot and Socket Joint

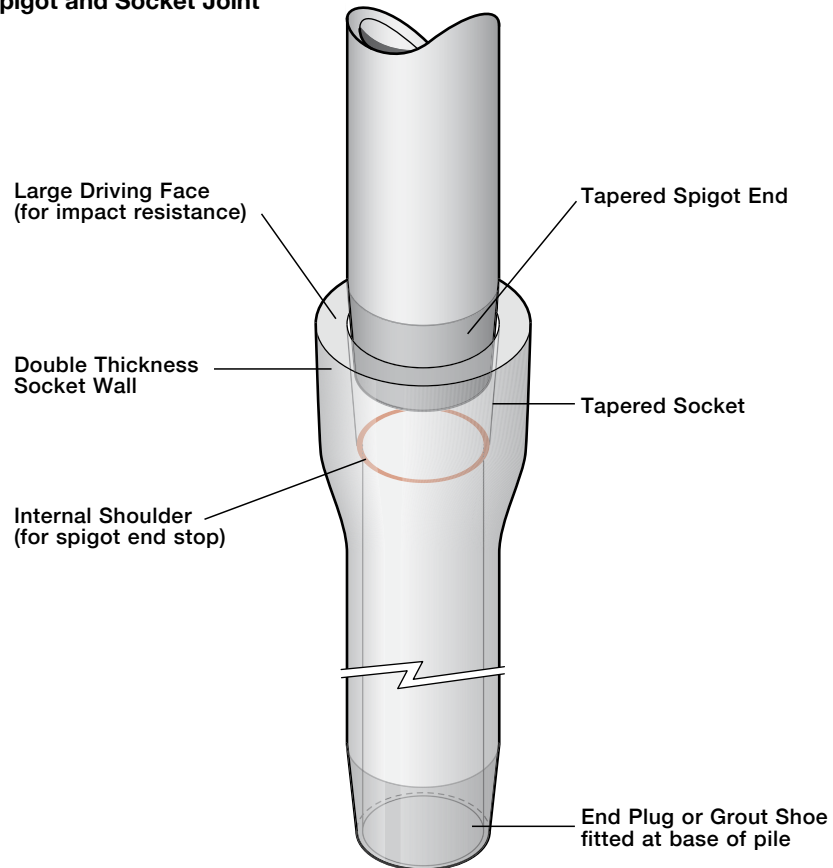

### Driving a ductile pile

The low mass of the individual pile sections means that piles can be driven with a light and versatile hydraulic excavator using a rapid-stroke hydraulic hammer. This permits pile foundations to be constructed where site conditions are difficult or space is limited.

With DYWIDAG Ductile Iron Piles high bearing capacities can be obtained with a rapid-stroke hammer operated at very low impact energies.

This results in smoother operations and almost vibration-free pile-driving

in the immediate vicinity of existing structures.

Pile placement is possible to within 40 cm of existing structures, and the use of excavators means that inclined piles can be placed at almost any rake.

#### Pile installation

The lead pile section is fitted with a pile shoe, and then pitched and driven. Additional pile sections are then added as required, to enable the pile to be driven to its full depth. The spigot and socket joint enables a very

quick connection of the individual pile sections.

The pile is driven to the required depth as calculated from penetration resistance, and any excess length is simply cut off with a disc cutter. The off-cut is then fitted with a new pile shoe and used as the first section of the next pile, resulting in no wastage. When pile driving is finished, the piles are filled with concrete to increase their bearing capacity and, depending on the loads required, the pile head is fitted with a pile cap or reinforcing cage.

## Driven Piles with Subsequent Placement of Concrete (typically end-bearing piles)

Installation of the Driven Ductile Iron Pile is one of the quickest and simplest piling methods available. The pile is driven to a “set” in dense gravel or on to bedrock. Concrete is then placed into the bore of the pile to give additional strength.

An end plug or rock point is fitted to the lead section, which is then driven to its full length, with additional sections added as required.

The set is defined as the reduced rate of pile penetration, in relation to a sustained driving energy (of the hammer), over a given time. Achievement of the set, demonstrates the pile’s ability to sustain its design load on a long term basis.

The value for the set (i.e. penetration rate in relation to sustained driving energy) is determined from empirical data, correlated with static load test results, in a range of different ground conditions over many years.

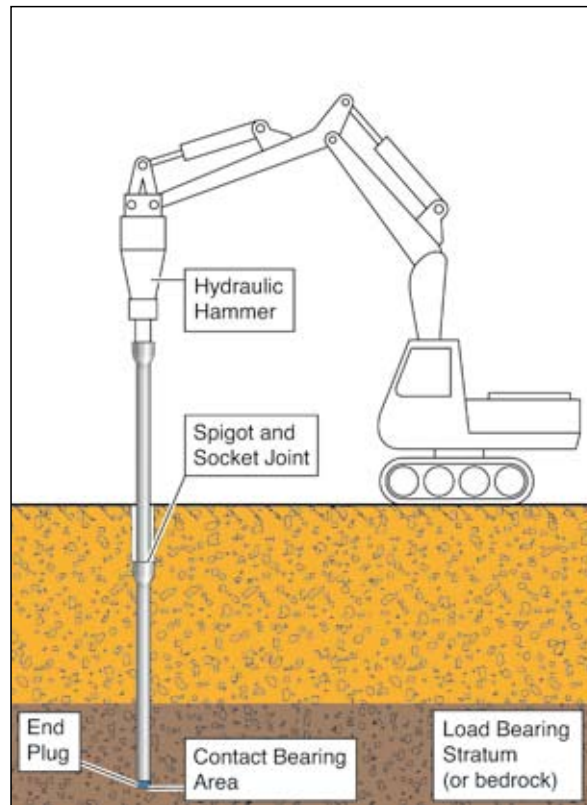

## Driven Piles with Grouted Annulus (typically skin friction piles)

Grouted driven piles combine the installation benefit of a driven pile with the flexibility of a grouted system.

An oversize grout shoe is fitted to the base of the lead pile section. As the pile is driven into the ground, the oversize shoe creates an annulus between the pile shaft and the ground,

which is constantly filled with a pile-concrete, to mobilise skin friction.

Installed by the simultaneous drive and grout technique, grouted piles can be also used in ground conditions where other systems are not suitable (i.e. high ground water or contaminated sites).

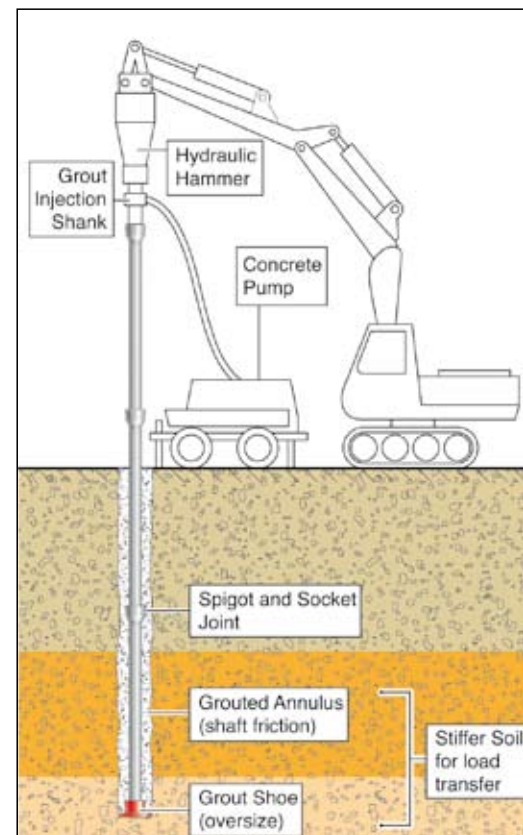

## Accessories

### End plug

End plugs are the standard pile-caps for non-grouted piles.

### Rock Point

Rock points are an alternative to end plugs, if the non grouted piles are driven through a harder material, e.g. weathered rock

### Grout shoe

Grout shoes are used if a grouted pile is installed. Grout shoes have a bigger

diameter than the pile, creating an annulus around the pile, which enables the placement of fine-aggregate concrete over the full length of the pile shaft.

### Coupler

Couplers can be used if two short pile sections must be connected in the place of the standard spigot and socket joint, e.g. if piles are driven in limited head room applications where the pile sections have to be cut.

### Pipeline saddle

The pipeline saddle enables the DYWIDAG Ductile Iron Pile to be used as a support to pipelines in poor ground. The saddle provides uniform support for five pipe diameters from 200 to 500 mm.

### Bearing plate

The bearing plate is the standard fitting for compression piles. A center hole in the plate is required, to fix the plate horizontally with a dowel, to ensure correct alignment when casting the pile cap or beam.

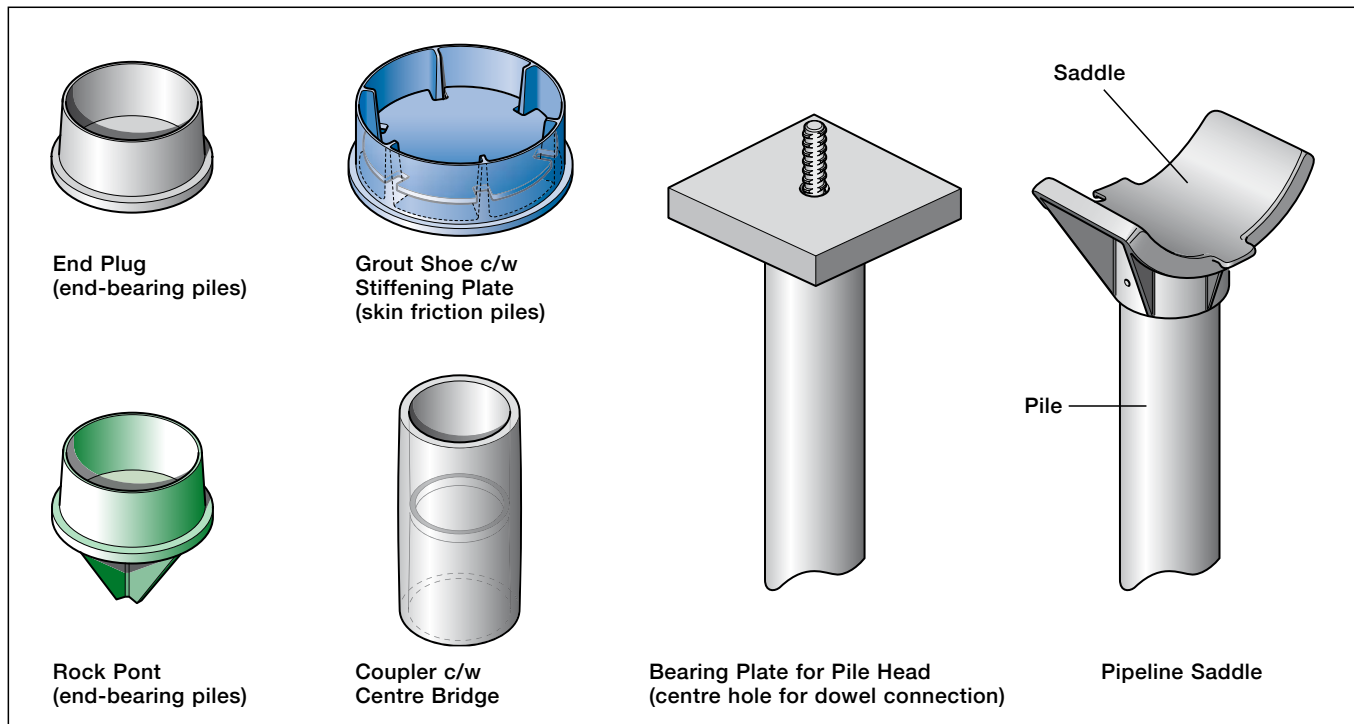

### Grout injection shank with grout box

Used for installation of grouted piles. Piling mix concrete (with a max. aggregate size of 4 mm) is pumped through the pile as it is driven, ensuring that the annulus between the pile shaft and the ground is fully grouted

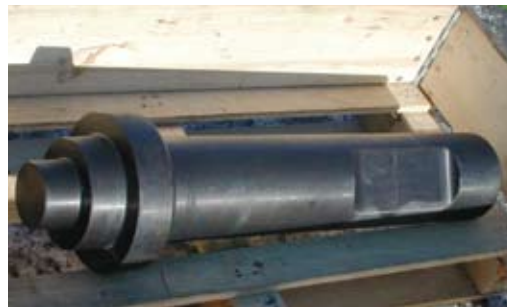

### Dry driving shank

Used for installation of end bearing piles. The dry driving shank is fitted into the excavator hammer, in place of the standard chisel. Piles are driven to a set and then filled with the pile concrete

# Applications

## Housing apartments or factory units

With working loads between 500 and 1.300 kN, the DYWIDAG Ductile Iron Piles offer comparable loads to conventional mini piles.

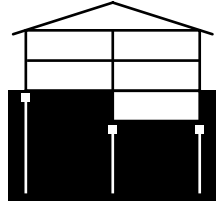

## Pylons or Wind Turbines

Power transmission towers can be built on small foundations, which transfer the vertical loads into the ground via the DYWIDAG Ductile Iron Piles.

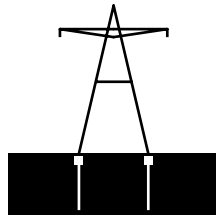

## Pipeline support

Pipelines can be laid easily, precisely and free of settlements on special pipeline saddles, which can be mounted directly onto the DYWIDAG Ductile Iron Piles.

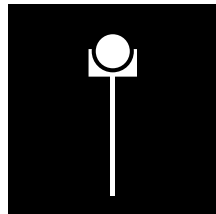

## Infrastructure projects

DYWIDAG Ductile Iron Piles are used for the foundations and the strengthening of new or existing roads, railway lines and bridges.

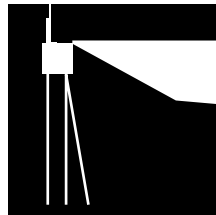

## Material

Ductile cast iron is a development of gray cast iron, a material which has been used for pipeline construction for centuries because of its high

resistance against chemical and mechanical influences. Through its very high ductility, the ductile cast iron is capable of withstanding the high

impact energies of the pile driving process.

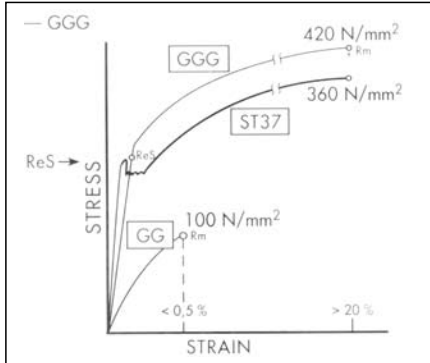

Stress strain diagram of the ductile iron used for the piles in comparison with gray cast iron and construction steel (left), and magnified microstructure of the ductile cast iron with its typical spheroidal graphite (right).

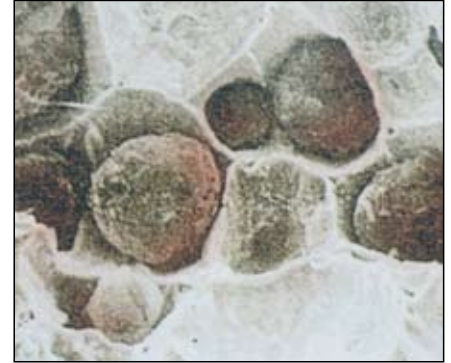

### ► Specifications

Pile tube OD Ø	Pile tube s	length	weight per tube	cross section	tensile strength	yield strength	ultimate load	yield load	section modulus	moment of inertia
[mm]	[mm]	[mm]	[kg]	[mm <sup>2</sup> ]	[N/mm <sup>2</sup> ]	[N/mm <sup>2</sup> ]	[kN]	[kN]	[cm <sup>3</sup> ]	[cm <sup>4</sup> ]
118	7,5	5.000	105	2.604	420	300	1.093	781	68	399
118	9,0	5.000	123	3.082	420	300	1.294	925	78	461
118	10,6	5.000	142	3.576	420	300	1.502	1.073	88	521
170	9,0	5.000	186	4.552	420	300	1.912	1.366	174	1.480
170	10,6	5.000	213	5.308	420	300	2.229	1.592	199	1.693

### ► Internal load bearing capacity in accordance with EC4

Pile type Ø x s [mm]	Ductile Iron grade 300/420		Concrete			Admissible pile load			
	[mm <sup>2</sup> ]	[kN]	[mm <sup>2</sup> ]	C20/25 [kN]	C25/30 [kN]	C30/37 [kN]	C20/25 [kN]	C25/30 [kN]	C30/37 [kN]
118 x 7,5	2.604	526	8.332	82	103	123	608	629	649
118 x 9,0	3.082	623	7.854	78	97	116	700	720	739
118 x 10,6	3.577	723	7.359	73	91	109	795	813	832
170 x 9,0	4.553	920	18.145	179	224	269	1.099	1.144	1.189
170 x 10,6	5.309	1.072	17.389	172	215	258	1.244	1.287	1.330

Values for the internal load bearing capacity which are calculated in accordance with national standards or approvals may vary slightly.

### ► Note

The values for the admissible pile loads have been calculated in accordance with EC4 with the assumption that the pile is loaded with 100% dead load, i.e. with a factor of safety for the loads of  $\gamma_F = 1,35$ . If the pile is loaded with a combination of dead and live load, the admissible pile load has to be reduced by the factor  $\alpha$ :

$$\alpha = \frac{p_{dead} \cdot 1,35 + p_{live} \cdot 1,5}{1,35}$$

with:

—  $p_{dead}$  : proportion of deaload

—  $p_{live}$  : proportion of live load

Example:

If a pile is loaded with 70% dead load and 30% live load, then the pile loads from the table have to be reduced by

$$\alpha = \frac{0,70 \cdot 1,35 + 0,30 \cdot 1,5}{1,35}$$

= 1,0333, i.e. by 3,33%

## Corrosion Assessment for DYWIDAG Ductile Iron Piles

Non-grouted piles are exposed to the surrounding ground, thus certain corrosion rates for the piles have to be considered.

Most of the existing tables for corrosion of piles and/or sheet piles are set up for steel components. Cast iron behaves differently with respect to corrosion. First of all the corrosion speed of cast iron is generally lower and secondly the casting crust is an additional barrier which slows corrosion.

In Austria, where the Driven Ductile Iron Piles have been used for many years, sacrificial corrosion values are published in the standard ONR 22567 (as determined by MA39, i.e. Material Testing Authorities, Vienna).

The tables below show the admissible pile loads, calculated in accordance with EC4 and taking the corrosion-assessment of ONR 22567 into account.



### ► Admissible Pile loads for pressure grouted piles and piles in soils up to corrosivity class AS1 (very low aggressiveness) pursuant to ÖNORM B 5013-1

Pile type Ø x s [mm]	Ductile Iron grade 300/420		Concrete			Admissible pile load*)			
	[mm <sup>2</sup> ]	[kN]	[mm <sup>2</sup> ]	C20/25 [kN]	C25/30 [kN]	C30/37 [kN]	C20/25 [kN]	C25/30 [kN]	C30/37 [kN]
118 x 7,5	2.604	526	8.332	82	103	123	608	629	649
118 x 9,0	3.082	623	7.854	78	97	116	700	720	739
118 x 10,6	3.577	723	7.359	73	91	109	795	813	832
170 x 9,0	4.553	920	18.145	179	224	269	1.099	1.144	1.189
170 x 10,6	5.309	1.072	17.389	172	215	258	1.244	1.287	1.330

\*) see note on bottom of page 8

### ► Admissible Pile loads for piles in soils up to corrosivity class AS2 (medium aggressiveness) pursuant to ÖNORM B 5013-1

Pile type Ø x s [mm]	Ductile Iron grade 300/420		Concrete			Admissible pile load*)			
	[mm <sup>2</sup> ]	[kN]	[mm <sup>2</sup> ]	C20/25 [kN]	C25/30 [kN]	C30/37 [kN]	C20/25 [kN]	C25/30 [kN]	C30/37 [kN]
118 x 7,5	2.328	470	8.332	82	103	123	553	573	594
118 x 9,0	2.806	567	7.854	78	97	116	644	664	683
118 x 10,6	3.300	667	7.359	73	91	109	739	758	776
170 x 9,0	4.154	839	18.145	179	224	269	1.018	1.063	1.108
170 x 10,6	4.910	992	17.389	172	215	258	1.164	1.207	1.250

\*) see note on bottom of page 8

### ► Admissible Pile loads for piles in soils up to corrosivity class AS3 (high aggressiveness) pursuant to ÖNORM B 5013-1

Pile type Ø x s [mm]	Ductile Iron grade 300/420		Concrete			Admissible pile load*)			
	[mm <sup>2</sup> ]	[kN]	[mm <sup>2</sup> ]	C20/25 [kN]	C25/30 [kN]	C30/37 [kN]	C20/25 [kN]	C25/30 [kN]	C30/37 [kN]
118 x 7,5	1.875	379	8.332	82	103	123	461	482	502
118 x 9,0	2.353	475	7.854	78	97	116	553	572	592
118 x 10,6	2.848	575	7.359	73	91	109	648	666	684
170 x 9,0	3.497	706	18.145	179	224	269	886	931	975
170 x 10,6	4.253	859	17.389	172	215	258	1.031	1.074	1.117

\*) see note on bottom of page 8

## References

### First Use of DYWIDAG Ductile Iron Piles in France *Stabilization of a road connection in the Pyrenees*

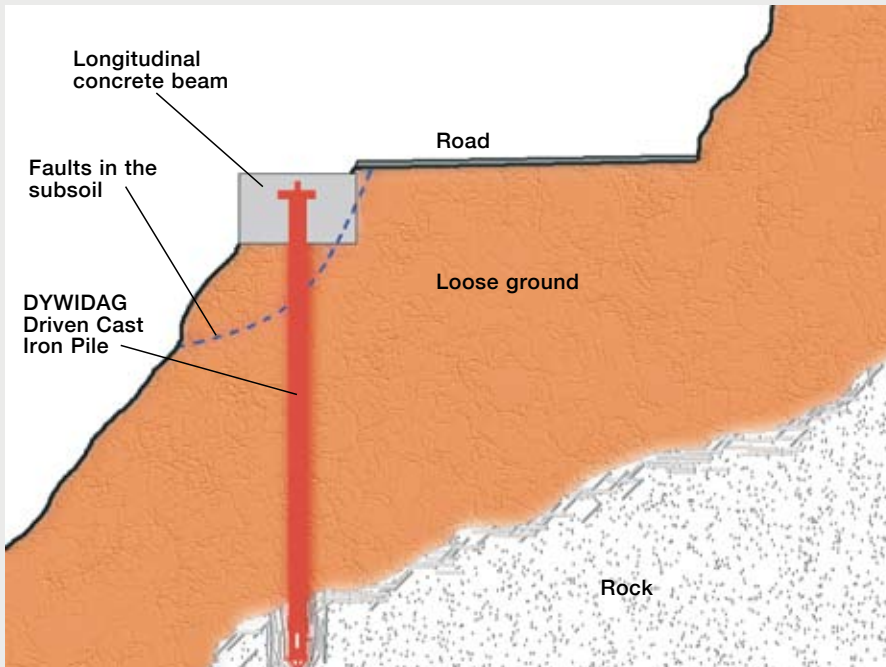

**i** **Owner** Department Council of the High Pyrenees, France +++ **Contractor** Cabinet d'Etudes technique Jean Frugier, France +++  
**Company** LTP, France  
**DSI Services** Supply of DYWIDAG Ductile Iron Piles with an overall length of 160 m, Ø 170 mm and accessories, technical assistance

### Noerpel Forwarding Agency Warehouse, Ulm



**i** **Client** Motz Construction Co.  
**DSI Services** Supply of 865 DYWIDAG Ductile Iron Piles, 6.500 m, skin-grouted

## References

---

### Furnishing House Gamerdinger, Böblingen



**i** Client Keller Grundbau  
DSI Services Supply of 332 DYWIDAG Ductile Iron Piles, 3.500 m, not-grouted

---

### Housing Apartments, Monaghan, Ireland



**i** Client PJ Edwards  
DSI Services Supply of 36 DYWIDAG Ductile Iron Piles, each 12-15 m long, non-grouted, technical support and site supervision

---

**Austria**

DYWIDAG-SYSTEMS  
INTERNATIONAL GMBH  
Wagram 49  
4061 Pasching/Linz, Austria  
Phone +43-7229-61 04 90  
Fax +43-7229-61 04 980  
E-mail: [alwag@dywidag-systems.com](mailto:alwag@dywidag-systems.com)  
[www.alwag.com](http://www.alwag.com)

DYWIDAG-SYSTEMS  
INTERNATIONAL GMBH  
Teichweg 9  
5400 Hallein, Austria  
Phone +43-6245-87 23 0  
Fax +43-6245-87 23 08 0  
E-mail: [sekretariat@dywidag-systems.at](mailto:sekretariat@dywidag-systems.at)  
[www.dywidag-systems.at](http://www.dywidag-systems.at)

**Belgium and Luxembourg**

DYWIDAG-SYSTEMS  
INTERNATIONAL N.V.  
Industrieweg 25  
3190 Boortmeerbeek, Belgium  
Phone +32-16-60 77 60  
Fax +32-16-60 77 66  
E-mail: [info@dywidag.be](mailto:info@dywidag.be)

**France**

DSI-Artéon  
Avenue du Bicentenaire  
ZI Dagneux-BP 50053  
01122 Montluel Cedex, France  
Phone +33-4-78 79 27 82  
Fax +33-4-78 79 01 56  
E-mail: [dsi.france@dywidag.fr](mailto:dsi.france@dywidag.fr)  
[www.dywidag-systems.fr](http://www.dywidag-systems.fr)

**Germany**

DYWIDAG-SYSTEMS  
INTERNATIONAL GMBH  
Schuetzenstrasse 20  
14641 Nauen, Germany  
Phone +49-3321-44 18 32  
Fax +49-3321-44 18 18  
E-mail: [suspa@dywidag-systems.com](mailto:suspa@dywidag-systems.com)

DYWIDAG-SYSTEMS  
INTERNATIONAL GMBH  
Max-Planck-Ring 1  
40764 Langenfeld, Germany  
Phone +49-2173-79 02 0  
Fax +49-2173-79 02 20  
E-mail: [suspa@dywidag-systems.com](mailto:suspa@dywidag-systems.com)  
[www.suspa-dsi.de](http://www.suspa-dsi.de)

DYWIDAG-SYSTEMS  
INTERNATIONAL GMBH  
Germanenstrasse 8  
86343 Koenigsbrunn, Germany  
Phone +49-8231-96 07 0  
Fax +49-8231-96 07 40  
E-mail: [suspa@dywidag-systems.com](mailto:suspa@dywidag-systems.com)

DYWIDAG-SYSTEMS  
INTERNATIONAL GMBH  
Siemensstrasse 8  
85716 Unterschleissheim, Germany  
Phone +49-89-30 90 50-100  
Fax +49-89-30 90 50-120  
E-mail: [dsihv@dywidag-systems.com](mailto:dsihv@dywidag-systems.com)  
[www.dywidag-systems.com](http://www.dywidag-systems.com)

**Please note:**

This brochure serves basic information purposes only. Technical data and information provided herein shall be considered non-binding and may be subject to change without notice. We do not assume any liability for losses or damages attributed to the use of this technical data and any improper use of our products. Should you require further information on particular products, please do not hesitate to contact us.

**Italy**

DYWIT S.P.A.  
Via Grandi, 68  
20017 Mazzo di Rho (Milano), Italy  
Phone +39-02-93 46 87 1  
Fax +39-02-93 46 87 301  
E-mail: [info@dywit.it](mailto:info@dywit.it)

**Netherlands**

DYWIDAG-SYSTEMS  
INTERNATIONAL B.V.  
Veilingweg 2  
5301 KM Zaltbommel, Netherlands  
Phone +31-418-57 89 22  
Fax +31-418-51 30 12  
E-mail: [email@dsi-nl.nl](mailto:email@dsi-nl.nl)  
[www.dsi-nl.nl](http://www.dsi-nl.nl)

**Norway**

DYWIDAG-SYSTEMS  
INTERNATIONAL A/S  
Industrieveien 7A  
1483 Skytta, Norway  
Phone +47-67-06 15 60  
Fax +47-67-06 15 59  
E-mail: [manager@dsi-dywidag.no](mailto:manager@dsi-dywidag.no)

**Portugal**

DYWIDAG-SYSTEMS  
INTERNATIONAL LDA  
Rua do Polo Sul  
Lote 1.01.1.1-2B  
1990-273 Lisbon, Portugal  
Phone +351-21-89 22 890  
Fax +351-21-89 22 899  
E-mail: [dsi.lisboa@dywidag.pt](mailto:dsi.lisboa@dywidag.pt)

**Spain**

DYWIDAG SISTEMAS  
CONSTRUCTIVOS, S.A.  
Avenida de la Industria, 4  
Pol. Ind. La Cantuena  
28947 Fuenlabrada (MADRID), Spain  
Phone +34-91-642 20 72  
Fax +34-91-642 27 10  
E-mail: [dywidag@dywidag-sistemas.com](mailto:dywidag@dywidag-sistemas.com)  
[www.dywidag-sistemas.com](http://www.dywidag-sistemas.com)

**United Kingdom**

DYWIDAG-SYSTEMS  
INTERNATIONAL LTD.  
Northfield Road  
Southam, Warwickshire  
CV47 OFG, Great Britain  
Phone +44-1926-81 39 80  
Fax +44-1926-81 38 17  
E-mail: [sales@dywidag.co.uk](mailto:sales@dywidag.co.uk)  
[www.dywidag-systems.com/uk](http://www.dywidag-systems.com/uk)

ARGENTINA  
AUSTRALIA  
AUSTRIA  
BELGIUM  
BOSNIA AND HERZEGOVINA  
BRAZIL  
CANADA  
CHILE  
COLOMBIA  
COSTA RICA  
CROATIA  
CZECH REPUBLIC  
DENMARK  
EGYPT  
ESTONIA  
FINLAND  
FRANCE  
GERMANY  
GREECE  
GUATEMALA  
HONDURAS  
HONG KONG  
INDONESIA  
IRAN  
ITALY  
JAPAN  
KOREA  
LEBANON  
LUXEMBOURG  
MALAYSIA  
MEXICO  
NETHERLANDS  
NORWAY  
OMAN  
PANAMA  
PARAGUAY  
PERU  
POLAND  
PORTUGAL  
QATAR  
SAUDI ARABIA  
SINGAPORE  
SOUTH AFRICA  
SPAIN  
SWEDEN  
SWITZERLAND  
TAIWAN  
THAILAND  
TURKEY  
UNITED ARAB EMIRATES  
UNITED KINGDOM  
URUGUAY  
USA  
VENEZUELA